

2MVIP-4MIR30Z-E 4MP VF Vandal-resistant Network IR Fixed Dome Camera



Key Features

Optics

- Day/night functionality
- Smart IR , up to 30 m (98 ft) IR distance
- IR anti-reflection window to increase the infrared transmittance
- 2D/3D DNR (Digital Noise Reduction)

Compression

- Ultra 265,H.265, H.264, MJPEG
- Triple streams

Network

- ONVIF Conformance

Structure

- Wide temperature range: -40°C to 60°C (-40°F to 140°F)
- Wide voltage range of $\pm 25\%$
- IK10 vandal resistant
- IP67

Specifications

	Manual Lens (Optional)	Motorized Lens			
Camera					
Sensor	1/3", 4.0 megapixel, progressive scan, CMOS				
Lens	2.8~12 mm, manual zoom lens		2.8~12 mm, motorized zoom lens		
DORI Distance	Lens	Detect(m)	Observe(m)	Recognize(m)	Identify(m)
	2.8mm	63	25.2	12.6	6.3
	12mm	270	108	54	27
Angle of View (H)	91.0°~27°				
Angle of View (V)	54.4°~13.7°				
Angle of View (O)	118.3°~33.2°				
Adjustment angle	Pan: 0°~360°		Tilt: 0°~90°		Rotate: 0°~360°
Shutter	Auto/Manual, 1/6~1/100000 s				
Minimum Illumination	Color: 0.02Lux (F1.6 AGC ON) 0 Lux with IR				
Day/Night	IR-cut filter with auto switch (ICR)				
Digital noise reduction	2D/3D DNR				
IR Range	Up to 30m (98 ft) IR range				
Defog	Digital Defog				
WDR	DWDR				
Video					
Video Compression	Ultra 265,H.265, H.264,MJPEG				
H.264 code profile	Baseline profile, Main Profile, High Profile				
Frame Rate	Main Stream:4MP (2048*1520): Max. 20fps; Sub Stream: 720P (1280*720): Max. 30 fps; Third Stream: D1 (704*576): Max. 30fps				
HLC	Supported				
BLC	Supported				
OSD	Up to 4 OSDs				
Privacy Mask	Up to 8 areas				
ROI	Up to 2 areas				
Motion Detection	Up to 4 areas				
Network					
Protocols	IPv4, IGMP, ICMP, ARP, TCP, UDP, DHCP, RTP, RTSP, RTCP, DNS, DDNS, NTP, FTP, UPnP, HTTP, HTTPS, SMTP, SSL , SNMP				
Compatible Integration	ONVIF(Profile S), API				
Interface					
Network	1 RJ45 10M/100M Base-TX Ethernet				
General					
Power	DC12V±25%, PoE (IEEE802.3 af)				
	Power consumption: Max 7.8W				
Dimensions (Ø x H)	Ø148 x 111.3 mm (Ø5.8" x 4.4")				
Weight	0.75 kg (1.7 lb)				
Working Environment	-40°C ~ +60°C (-40°F ~ 140°F), Humidity:10%~ 95% RH(non-condensing)				

Ingress Protection	IP67
Vandal Resistant	IK10
Reset Button	Supported

Dimensions

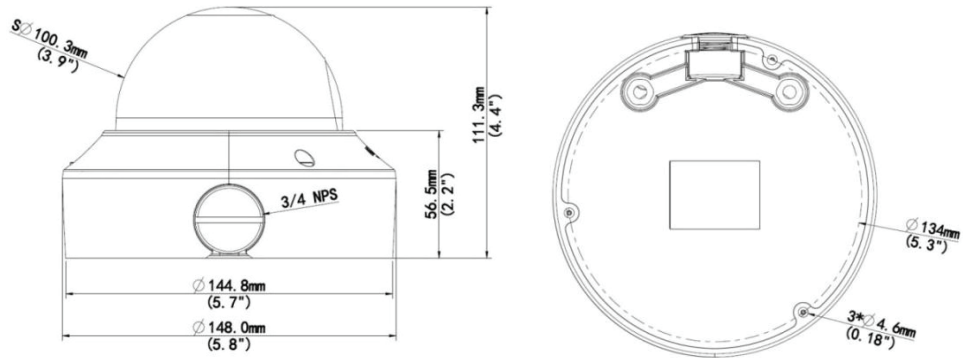

*Product specifications and availability are subject to change without notice.